

| | | |
|----------|--------------------|-------------------------------------------------------------------------------------|
| CAPACITY | SYMBOL/ SERIAL NO. | CIRCUIT DIAGRAM |
| DC 24V | |  |
| 40W x 1 | | |

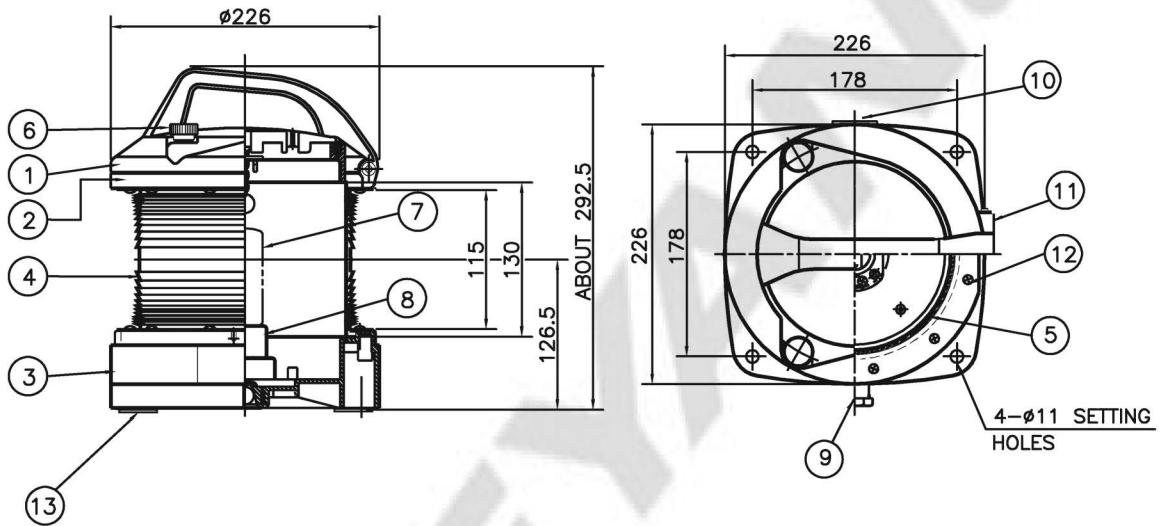

NOTE

1. APPLICATION RANGE : VESSEL OF 50M IN LENGTH AND ABOVE
2. MINIMUM VISIBILITY : 3 N.M
3. W/1.5M CABLE (TPNP 1.5SQ)

*** CAUTION!!**

Do not install the navigation light upside down.
 Since breathing device is installed on the bottom of fixture.
 (설치 시 주의하십시오. 항해등의 바닥에는 호흡기가 설치되어 있으므로 거꾸로 설치하지 마십시오.)

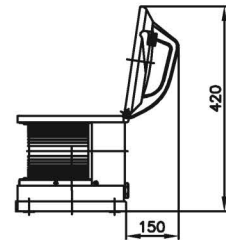

MAINTENANCE SPACE

| 13 | ANTI-VIBRATION PACKING | C.R. | 4 | 5mm | | | | | |
|----|------------------------|----------------------|------|-----------------|----|---------------|-----------------|------|---------|
| 12 | T/H TAPPING SCREW | STAINLESS STEEL 304 | 24 | M4 | 6 | CLAMP BOLT | BRASS | 2 | |
| 11 | HINGE | POLYCAR-BONATE | 1 | | 5 | GASKET | SILICONE RUBBER | 1 | |
| 10 | NAME PLATE | STAINLESS STEEL 316L | 1 | | 4 | LENS | POLYCAR-BONATE | 1 | RED |
| 9 | CABLE GLAND | NYLON | 1 | #20a~c (φ12~15) | 3 | BODY | POLYCAR-BONATE | 1 | |
| 8 | LAMP HOLDER | PPS | 1 | P28s | 2 | TOPPER | POLYCAR-BONATE | 1 | |
| 7 | NAVIGATION LIGHT LAMP | - | 1 | P28s | 1 | COVER | POLYCAR-BONATE | 1 | |
| NO | NAME OF PARTS | MATERIAL | Q'TY | REMARKS | NO | NAME OF PARTS | MATERIAL | Q'TY | REMARKS |

| | | | | | | | | | |
|-------------------------------------------------------------------------------------|------------|-------|-----------|--------------------------------------------------|-----------------------|-----------|--------|--|--|
| APPROVED | B. K. KIM | UNIT | MM | TITLE; RED LIGHT FOR MARINE USE | | | | | |
| CHECKED | | SCALE | N/S | | | | | | |
| DRAWING | B. I. KIM | COLOR | MAT BLACK | | | | | | |
| DATE | 2015.12.04 | IP | 56 | | | | | | |
|  | | | | MODEL NO. | A2P-SR4024Hh-1.5M-MED | WEIGHT | 2.9 kg | | |
| | | | | DWG NO. | L31160102 | SHEET NO. | 25 | | |